

# On synthesis of power regulator controllers of arc furnaces according to desired regulating characteristics

V A Ivanushkin<sup>1</sup>, D V Isakov<sup>1</sup>, S E Mironov<sup>2</sup> and F N Sarapulov<sup>3</sup>

<sup>1</sup>Associate Professor, Ural Federal University (branch), Nizhniy Tagil, Russian Federation.

<sup>2</sup>Associate Professor, Ural Federal University, Ekaterinburg, Russian Federation.

<sup>3</sup>Professor, Ural Federal University, Ekaterinburg, Russian Federation.

E-mail: [atps\\_nt@mail.ru](mailto:atps_nt@mail.ru),

**Abstract.** The paper considers a synthesis method of power regulator controllers of electric arc furnaces on the basis of unit typical non-linear functions; the main stages of synthesis of control devices; the mathematical model of the basic elementary unit of nonlinearities; the presented modular structure of the control unit of the power regulator of an arc furnace.

## 1. Introduction

With the use of programmable logic controllers (PLC) and modern variable-frequency electric AC drives in automatic power regulators of electric arc furnaces there have appeared new possibilities to improve quality of electric mode control and core technical and economic indicators of furnace operation.

It is known that the quality of the electric mode control system of the furnace is mainly defined by regulating characteristics (relations of free running electrode speed in the function of misalignment signal) of the electrode movement drive [1]. Implementation of desired regulating characteristics in the acting regulators was traditionally enforced within the capabilities of the electrode drive control system. Under this approach addressing the targeted task was narrowed down to applying negative nonlinear feedback in the drive coordinates (speed and voltage of the supply converter, etc.), as well as to including nonlinear functional converters in the direct transmission (mainly, in terms of the dead zone) [1]. Such approach inevitably resulted in necessity for designing special-purpose electrode drives that completed two tasks: controlling the drive coordinates as such and setting the object control law (relay, proportional, proportional-relay, or a more complex one).

At the present time during new detail engineering and upgrading operating mechanisms of power regulators of electric arc steelmaking furnaces using four-quadrant drives (for example, complete variable-frequency) it is rational to impose on the programmable logic controllers a task of formation of the desired regulating characteristics adapted to different melting periods. In this case the developer of the arc automatic regulator controller considers the complete controlled drive as an element that refers to the unalterable part of the controlled entity, thereby there is no longer any necessity to propose any needed changes in accordance with requirements to the structure and algorithms of the electric drive control system. Besides, in this particular case the developer of controllers brings into focus not the electric drive system coordinates control, but the implementation of the control algorithm of the definite process flow stage.



Under this approach there appears a task of choosing the representation and synthesis of different regulating characteristics (both symmetrical and asymmetrical) of the regulator controllers adopted to different melting process technological periods. In paper [2] there are stated the basic approaches to develop the power-efficient control algorithms of the electrical mode of the direct electric arc steelmaking furnaces taking into account the possible availability of modern PLC. The same article specifies the desired regulating characteristics of the automatic power regulators for different melting process periods containing piecewise-linear and piecewise-constant areas. Paper [3] suggests a method of analytical description of the similar non-linear functions of the regulators using function type sign (X) and abs (X) requiring the preliminary partition of the initial non-linear function to elementary standard components and their mathematical description.

Besides this, while the power regulators regulating characteristics being developed there arises a task of implementing non-specific non-linear functions for example when making an assessment and eliminating residual misalignment signal, as well as implementing smart regulation during furnace charge melt regime, the following non-linear functions are used: three-step relay characteristics along with the dead zone, sign selection, dead zone offset, etc [4,5,6,7].

## 2. The implementation of power regulators arc furnace

Practice shows that when using the mentioned method complex non-linear dependences typical for arc furnace, power regulators are possible to put into practice if using unit non-specific non-linear functions. The proposed method of synthesis provides the sequential performance of the following stages:

1. Requiring the desired characteristics of the controller in graphical form (for example, as represented by Figure 1) containing piecewise-linear and piecewise-constant areas with the desired cut coordinates (setup variables  $a_i$ ,  $b_i$ ).
2. Decomposition of the initial characteristics to the composition of simple components (symmetrical elementary typical non-linears).
3. Analytical description of every component using the models of the basic elementary static and dynamic non-linear unit functions (Table 1).
4. Formatting unit elementary characteristics to the real scale on both axis (it is necessary because the full level of the output signal of the actual components of the desired characteristics is not a single one and the interval of their action has definite values).
5. Structuring block-modular construction of the controllers (Figure 2) and algorithmic schemes of its module.).

Table 1 represents the mathematical models of the basic elementary static and dynamic unit non-linears that are used while there being developed the specified characteristics (Figure 1) of the electromechanical regulator control of the electric arc furnace with the integrating actuating mechanism of the variable speed. The block-modular construction of the controllers is shown in Figure 2. The block consists of two subblocks I and II generating a control signal under positive and negative error mismatch (on lifting and lowering the electrode respectively), subblock III of the misalignment sign indication, as well as subblock IV of the continuous monitoring of the residual misalignment and regulator performance rating.

Subblock I contains modules 1-7 that generate the control action on the electrode movement drive under positive misalignment signal (module (7) in Figure 2. characteristic (b) in Figure 1) in mode of reversible and nonreversible control. Upon that, the reversible control mode is implemented with the help of modules 1-4 (characteristic (a) in figure 1, components (1,2,3,4) in figure 2) and module 6 (Figure 2, characteristic (g) in Figure 1), given that the external signal  $\alpha = 0$ ,  $\beta = 1$ . In nonreversible control mode (except for continuous short circuit fault) there is implemented non-type, mixed non-linear characteristics (characteristic (a) in figure 1, path  $-0 \rightarrow a4 \rightarrow b4 \rightarrow a3 \rightarrow b3 \rightarrow b2 \rightarrow b1 \rightarrow a1 \rightarrow 0$ ) with the help of the modules 1,2,3,4 and module 5 (characteristic (f) in Figure 1).

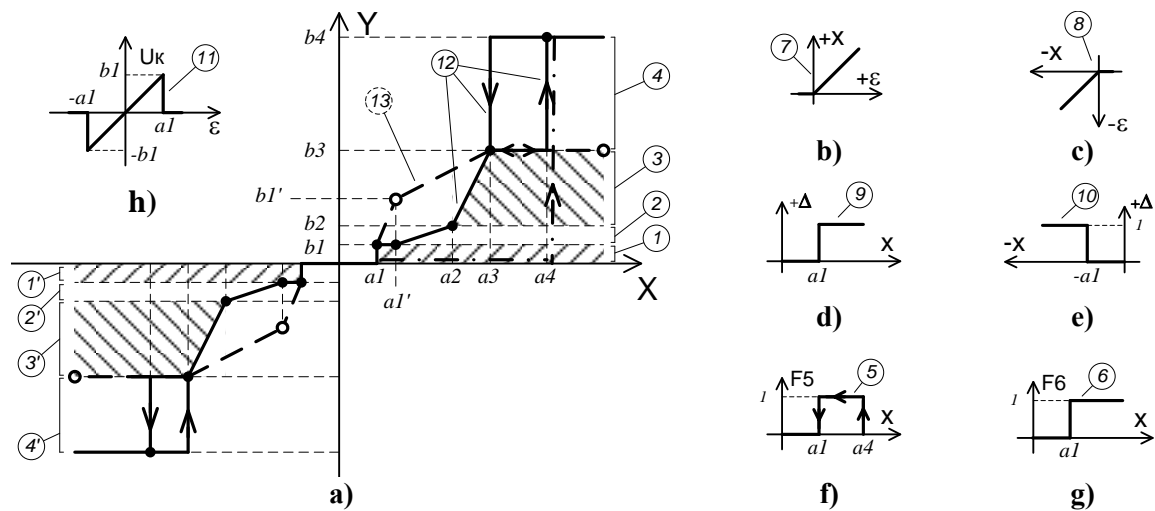

**Figure 1.** Statistic characteristics of the functional non-linear converter (a) main view with elementary non-linear components (1-4 modules of its block-modular construction (figure 2)); (b, c) selection of positive and negative misalignment (7, 8 modules of its block-modular construction (figure 2)); (d, e) misalignment sign indication (9, 10 modules of its block-modular construction (figure 2)); (f, g) implementing smart regulation (5, 6 modules of its block-modular construction (figure 2)); (h) control of the residual misalignments (11 modules of its block-modular construction (figure 2)).

**Table 1.** Elementary unit non-linears

Name of non-linear	Mathematical description (model)
Three-step relay characteristics	$f(x) = \frac{1}{2}[\text{sign}(x - a) + \text{sign}(x + a)]$
Output limit on dead zone offset	$f(x) = \frac{1}{2}( x + b  -  x - b  -  x + a  +  x - a ), \quad b > a$
Three-step relay characteristics with hysteresis	$f(x) = \frac{1}{2} \left[ \text{sign} \left( x - a \cdot \text{sign} \frac{dx}{dt} \right) + \text{sign} \left( x + b \cdot \text{sign} \left( x + b \cdot \text{sign} \frac{dx}{dt} \right) \right) \right]$ $b > a$
Selection of negative misalignment $\varepsilon$	$x(\varepsilon) = \frac{1}{2}(\varepsilon -  \varepsilon )$
Selection of positive misalignment $\varepsilon$	$x(\varepsilon) = \frac{1}{2}(\varepsilon +  \varepsilon )$
Three-step inverse relay characteristics	$f(x) = -\frac{1}{2}[\text{sign}(x - a) + \text{sign}(x + a)]$
Dead zone	$f(x) = \varepsilon - \frac{1}{2}( x + a  -  x - a )$
Output limit	$f(x) = \frac{1}{2}( x + a  -  x - a )$

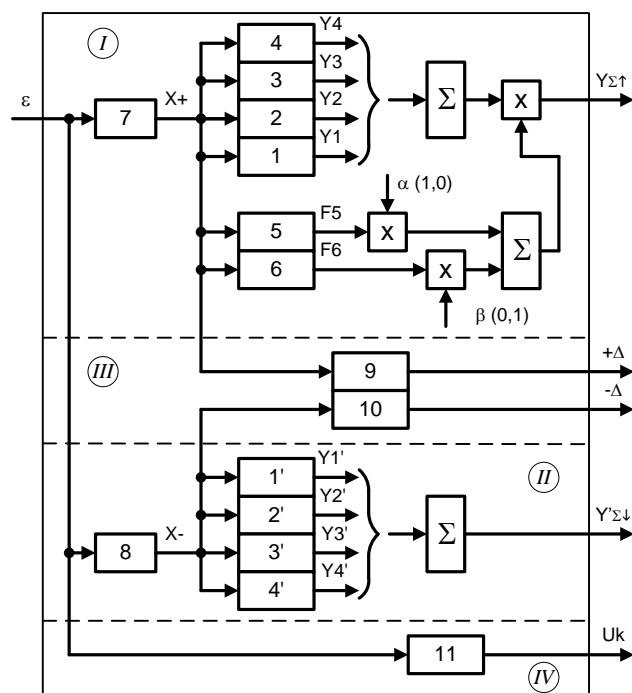

**Figure 2.** Block-modular construction of the controller.  
 I, II – subblocks of control signals formation under positive and negative misalignments;  
 III – subblock of sign misalignment indication;  
 IV – subblock of continuous misalignment monitoring and regulator performance rating.

The given mode setting condition is the presence of inverse values of the external signals  $\alpha$  and  $\beta$ . With the help of module 5 under positive misalignment signal lowering there is provided an automatic bypass from the relay control to the proportional one.

Subblock II contains modules 8 (Figure 2, characteristic (c) in Figure 1) and 1' - 4' providing the formation of the desired controls while regulator processing the negative misalignment signals.

Subblock III contains modules 9 and 10 and generates the signals:  $+\Delta$  – running of the regulated parameter over the upper bound of the dead zone (characteristic (d) in Figure 1);  $-\Delta$  - running of the regulated parameter over the lower bound of the dead zone (characteristic (e) in Figure 1).

Subblock IV contains one module 11 implementing non-type non-linear static characteristics (characteristics (h) in Figure 1).

Algorithmic structures of all the subblocks modules are developed on the basis of mathematical models in Table 1. Table 2 shows unit non-linears that are used while subblocks (1-4) modules are being developed, as well as the coordinates of their setup variables and formatting indexes.

**Table 2.** Parameters and indexes of formatting unit non-linears

No module	No.№ non-linears	X-coordinate	Y-coordinate	Formatting index
1	1	a1	b1	b1
2	2	a1, a2	b1, b2	b2 - b1 / a2 - a1
3	2	a2, a3	b2, b3	b3 - b2 / a3 - a2
4	3	a3, a4	b3, b4	b4 - b3
5	3	a1, a4	1	1
6	1	a1	1	1
7	4	0	0	1
8	5	0	0	1
9	1	a1	1	1
10	8	a1	1	1
11	7 + 8	a1	b1	b1

### 3. Conclusion

It must be noted that the models given in Table 1 make it possible to design the desired regulating characteristics of the automatic regulator with integrating constant speed actuators under relay control.

The applicability of the proposed approach to the synthesis of power regulators controllers of electric arc furnaces on the basis of the desired regulating characteristics is determined by advisability of their implementation on the programmable logic controllers base.

### References

- [1] Pirozhnikov V E and Kablukovskii A F 1974 *Avtomatizatsiia kontroliia i upravleniia elektrostaleplavil'nyimi ustanovkami* [Automation and control for electric arc furnaces plants] (Moscow: Metallurgii – Press)
- [2] Ivanushkin V A, Isakov D V, Sarapulov F N, Pozdeev S A and Rabek A A 2015 Formirovanie energo-effektivnykh algoritmov upravleniia elektricheskim rezhimom dugovykh staleplavil'nykh pechei [Developing power-efficient control algorithms of the steelmaking arc furnaces electrical mode] *Industrial Power Engineering* **7** 32-35
- [3] Ivanushkin V A, Isakov D V, Gamov A V and Sarapulov F N 2017 K realizatsii modelei upravliaiushchikh ustroystv s zadannymi regulirovochnymi kharakteristikami regulatorov moshchnosti dugovykh elektropechei [On implementing models of the controllers with set regulating characteristics of the arc furnaces power regulators] *Effektivnoe i kachestvennoe snabzhenie i ispol'zovanie energii: sb. dokl. 6-oi mezhdunar. konf. v ramkakh spetsializir. foruma «Expo Build Russia»* Ekaterinburg 126-129
- [4] Ivanushkin V A 1998 Regulator moshchnosti dugovoi elektropechi [Power control electric arc furnace] *Certificate of authorship USSR* no. 1365375
- [5] Ivanushkin V A 1988 Regulator moshchnosti dugovoi elektropechi [Power control electric arc furnace] *Certificate of authorship USSR* no. 1424702
- [6] Ivanushkin V A, Sarapulov F N, Isakov D V, Terekhov A Iu and Gamova T V 2012 Regulator moshchnosti dugovoi staleplavil'noi pechi [Power control electric arc furnace] *Patent Russia* no. 2448165
- [7] Ivanushkin V A, Sarapulov F N, Kozheurov V N and Isakov D V 2008 Regulator polozheniia elektroda dugovoi staleplavil'noi pechi [The position control electrode arc furnace] *Patent Russia* no. 2334926